

- instruções
- instructions
- instrucciones
- gebruiksaanwijzing

ZY

B A B Y

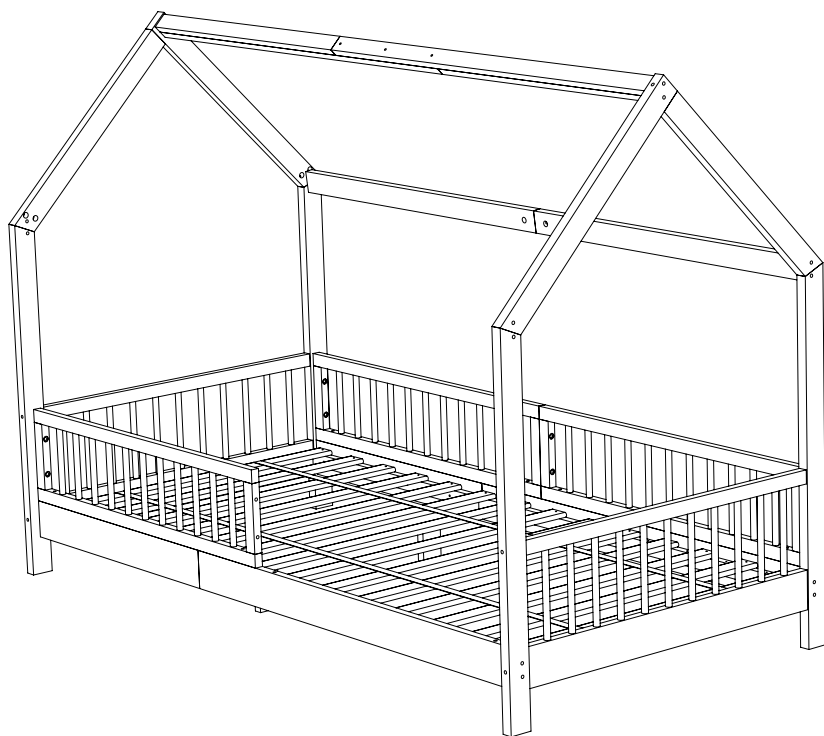

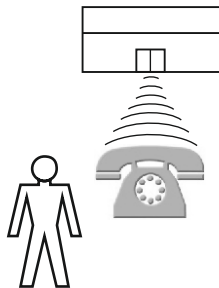
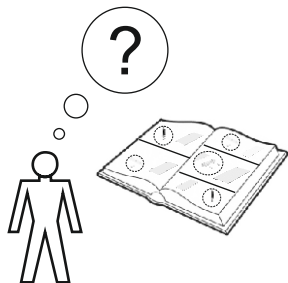
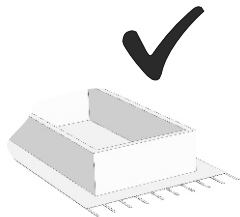
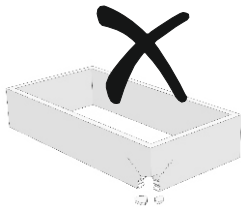

A montar pelo cliente
To be assembled by the purchaser
Para montar por el consumidor
À monter soi-même
In Kit



PT

Matéria-Prima: Pinho Natural

Acabamento do Produto:

Verniz ou Lacado (não tóxico)

GB

Raw Material: Wooden Pine

Finished Product Coated With:

Varnish or Painted (non-toxic)

ES

Materia Prima: Pino Natural

Producto terminado con acabado de:

Barniz o Pintura (no tóxicos)

FR

Matière Première: Pin

Produit Fini enduit de:

Vernis ou Peinture (non toxique)

NL

Basismateriaal: Grenen

Afgewerkt Product behandeld met:

Vernis of Verf (niet toxisch)

FERRAMENTAS NECESSARIAS



TOOLS REQUIRED





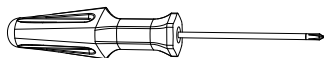



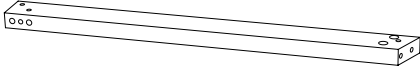
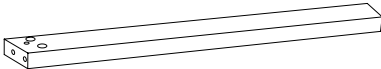
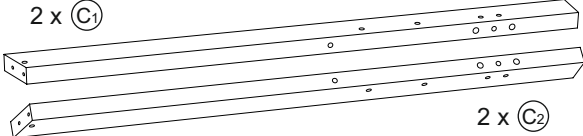
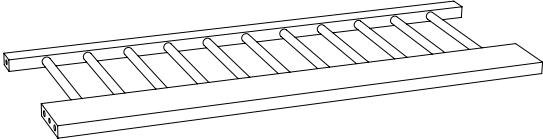
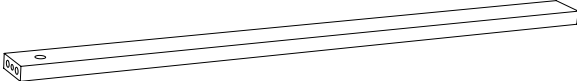
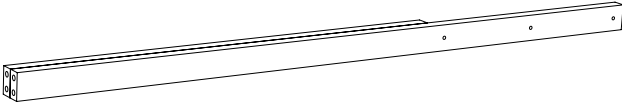
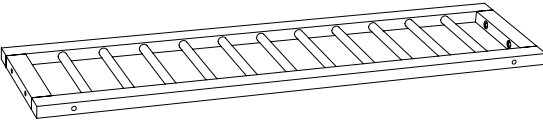
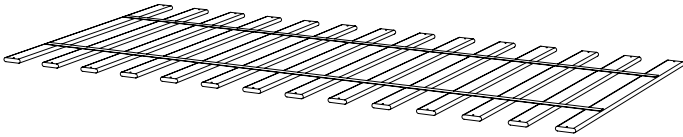
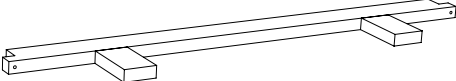
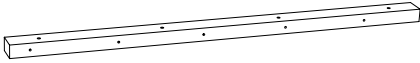

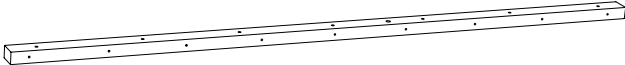
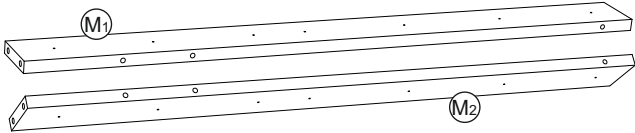
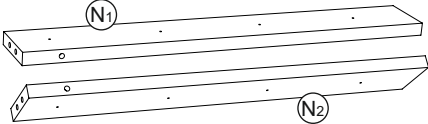

HERRAMIENTAS NECESARIAS









OUTILS NÉCESSAIRES

GEREEDSCHAP NODIG



	COMPONENTES • COMPONENTS COMPOSANTS • INHOUD		
(A)		72 x 6 cm	2
(B)		66 x 6 cm	2
(C)	2 x (C1)  2 x (C2)	95 x 6 cm	4
(D)		90 x 35 cm	2
(E)		96 x 6 cm	2
(F)		116 x 4,5 cm	2
(G)		96 x 25 cm	3
(H)		189 x 92 cm	1
(J)		92 x 17 cm	1
(K)		70 x 3,5 cm	2

	COMPONENTES • COMPONENTS COMPOSANTS • INHOUD		
(L)		120 x 3,5 cm	2
(M)		120 x 10 cm	2
(N)		72 x 10 cm	2
(P ₁)			8
(P ₂)			1
(R)			10
(Q ₁)		Ø10 x 45 mm	12
(Q ₂)		Ø10 x 60 mm	6
(Q ₃)		Ø8 x 35 mm	2
(S ₁)		M6 x 80 mm	10
(S ₂)		M6 x 60 mm	2
(S ₃)		M6 x 45 mm	28
(T)			2

	COMPONENTES • COMPONENTS COMPOSANTS • INHOUD		
(U)		27 mm	3
(V)		M4 x 25 mm	3
(W)		4 x 35 mm	30
(X)		4 x 40 mm	26
(Y)		4 mm	1

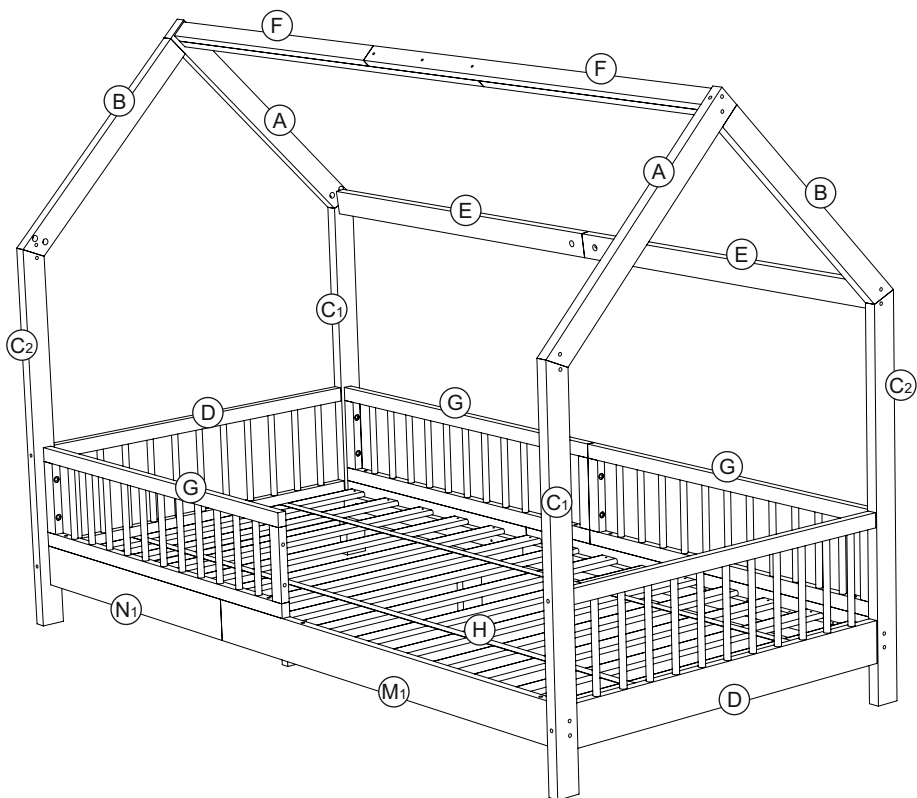

1

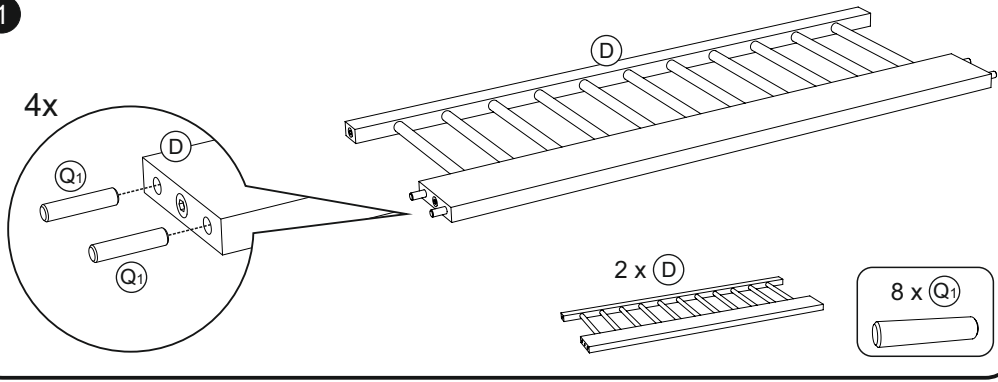

2

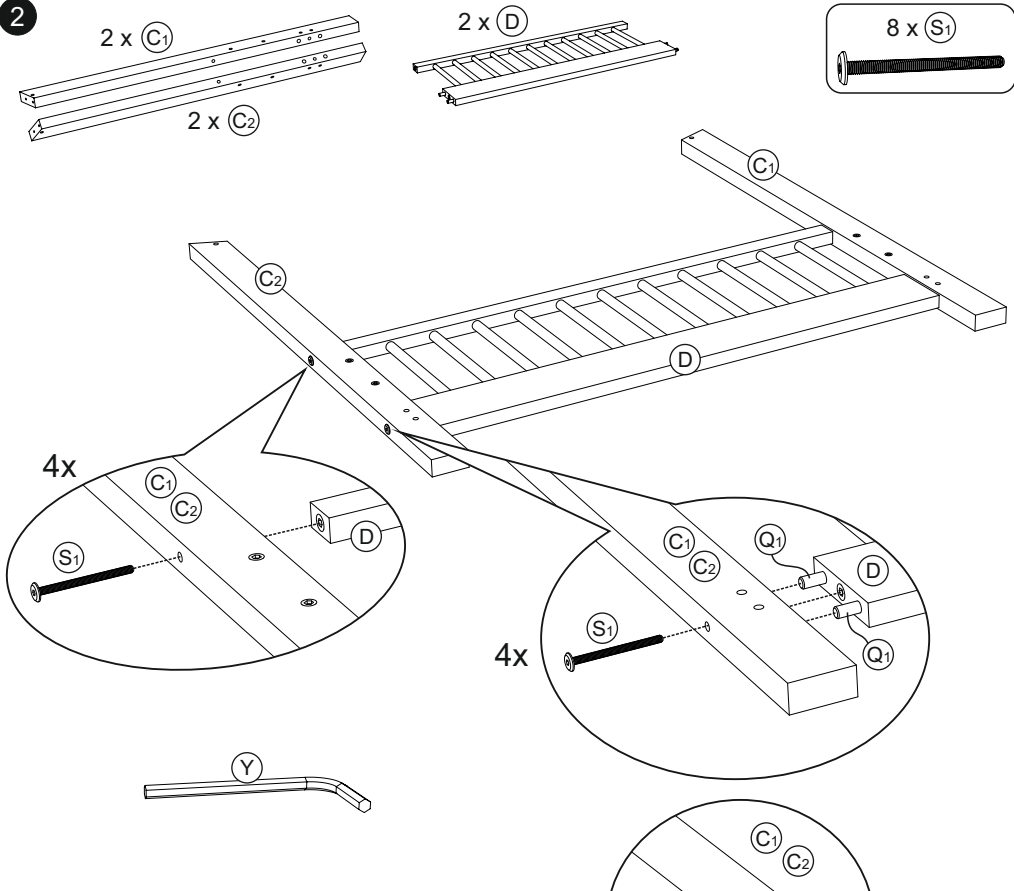

IMPORTANTE: Não Aperte os Parafusos Definitivamente
IMPORTANT: Do Not Fully Tighten Screws
IMPORTANTE: No Apriete Los Tornillos Completamente
IMPORTANT: Ne Pas Serrez Les Vis Complètement
BELANGRIJK: De Schroeven Niet Volledig Vastdraaien

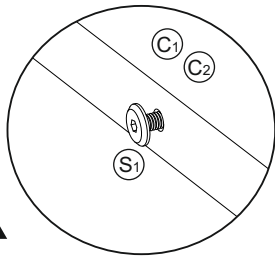

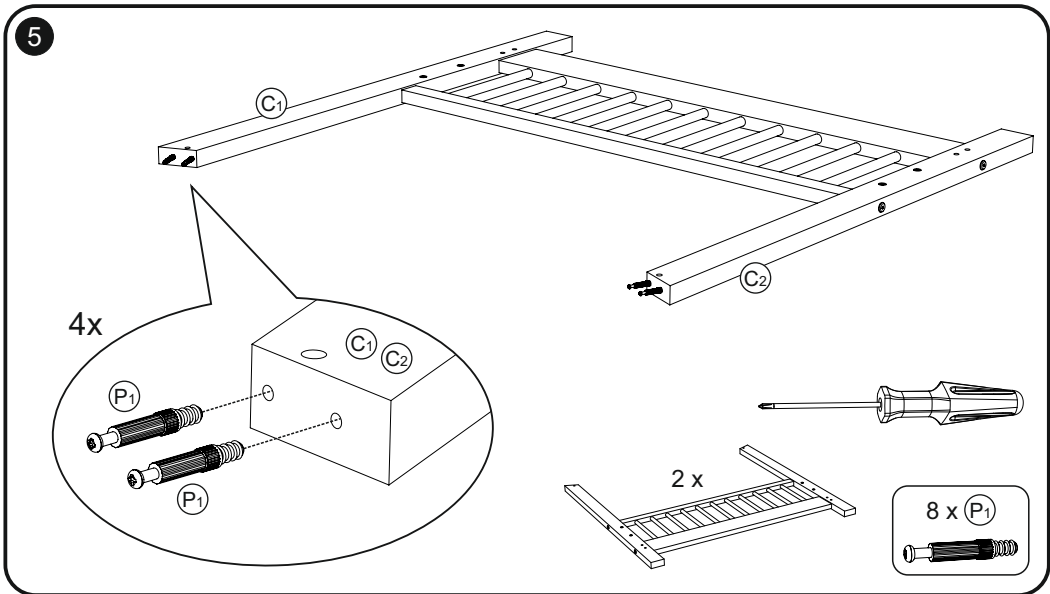
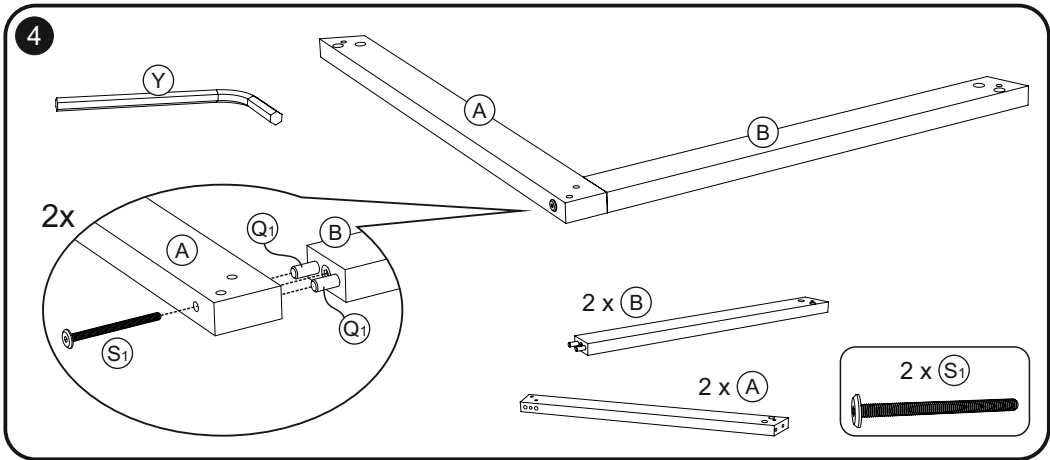
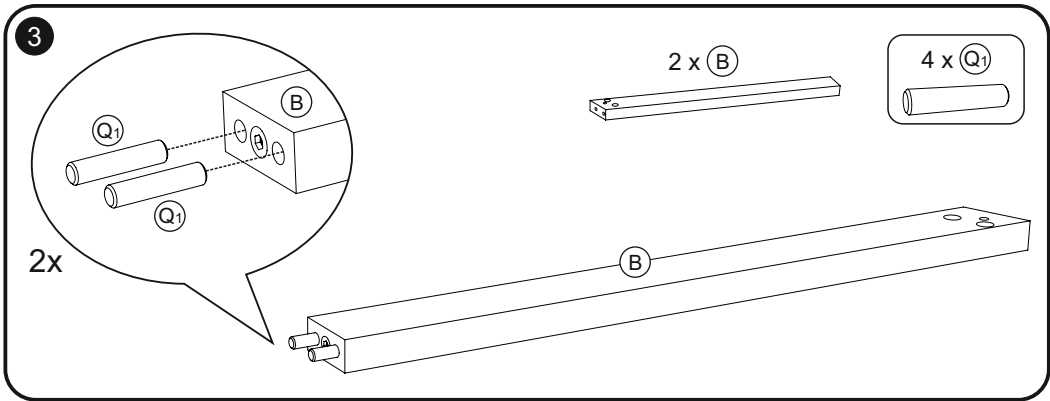

6

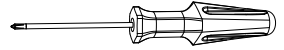
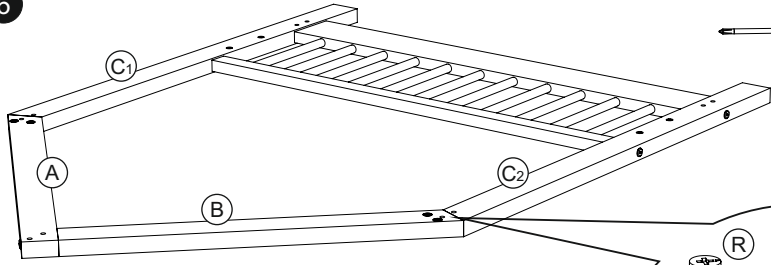

4x

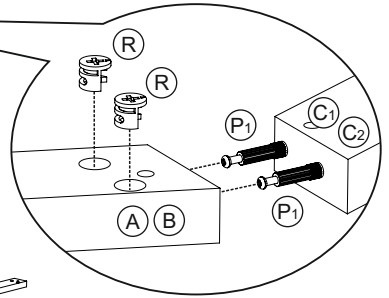

8 x (R)



2 x

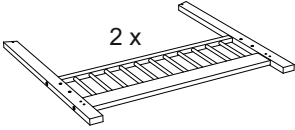

2 x

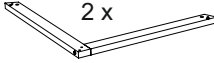

7

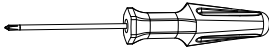

IMPORTANTE: Apertar Completamente
IMPORTANT: Tighten Completely
IMPORTANT: Apriete Completament
BELANGRIJK: Draai Volledig Vast

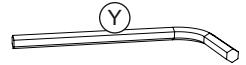
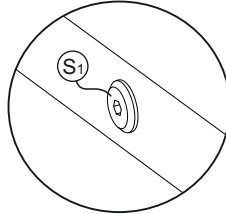
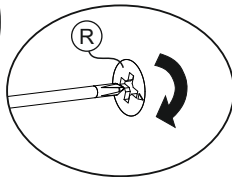
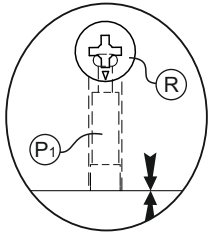

8

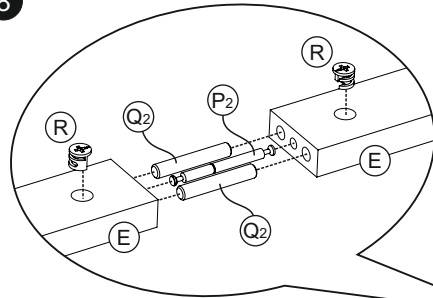

1 x (P₂)

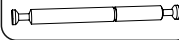

2 x (Q₂)

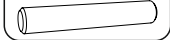

2 x (R)

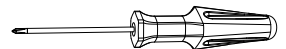
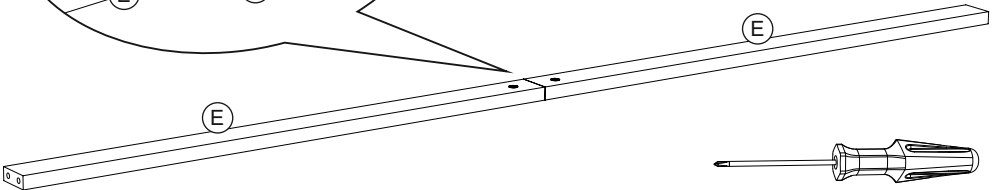

9

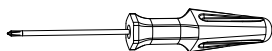
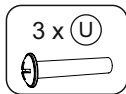
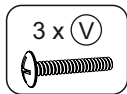
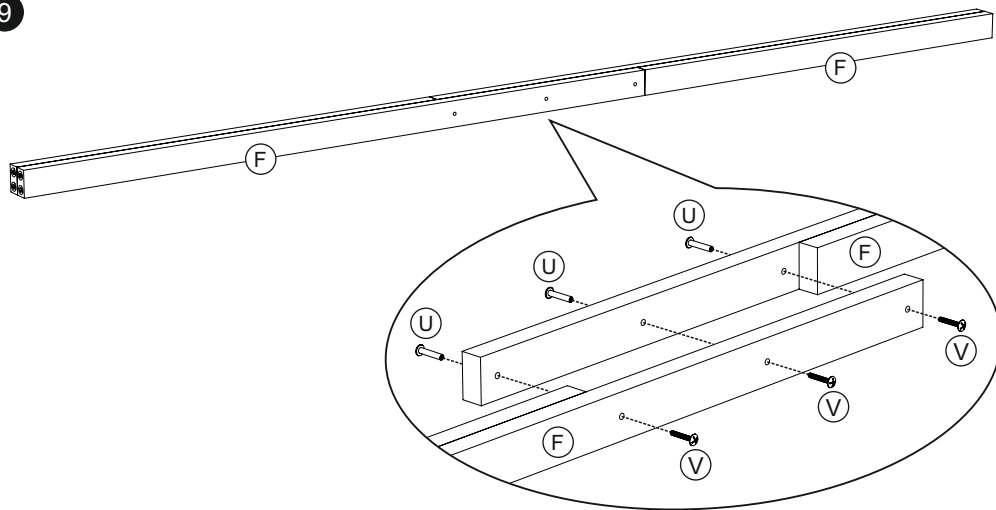

10

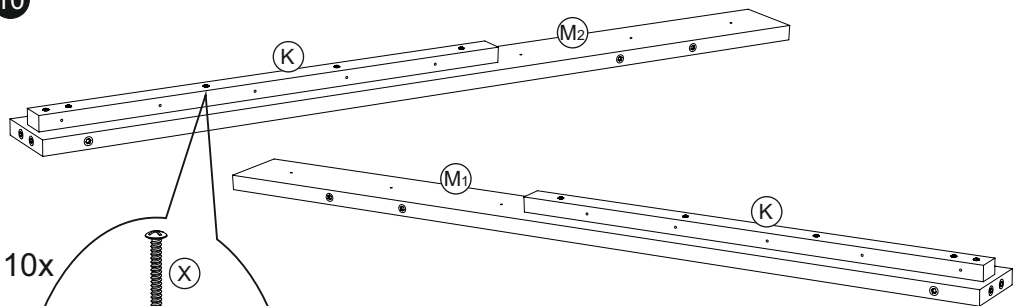

10x

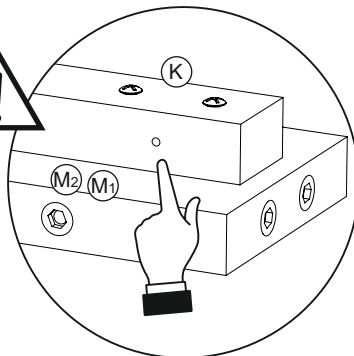
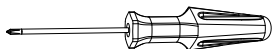
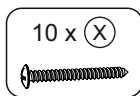
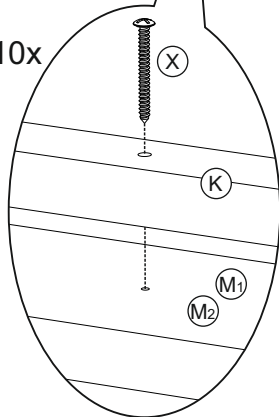

11

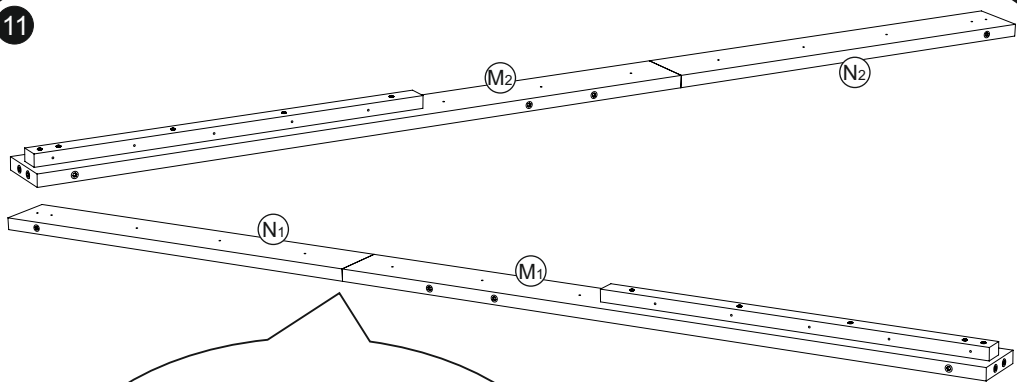

2x

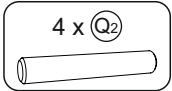
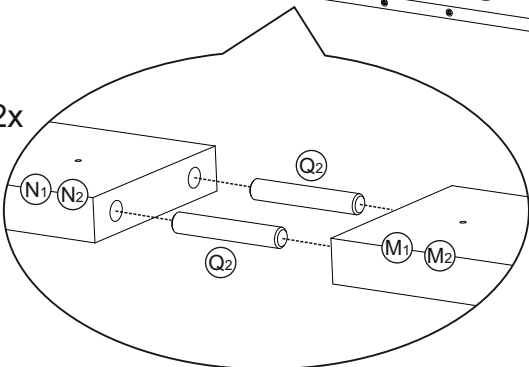

12

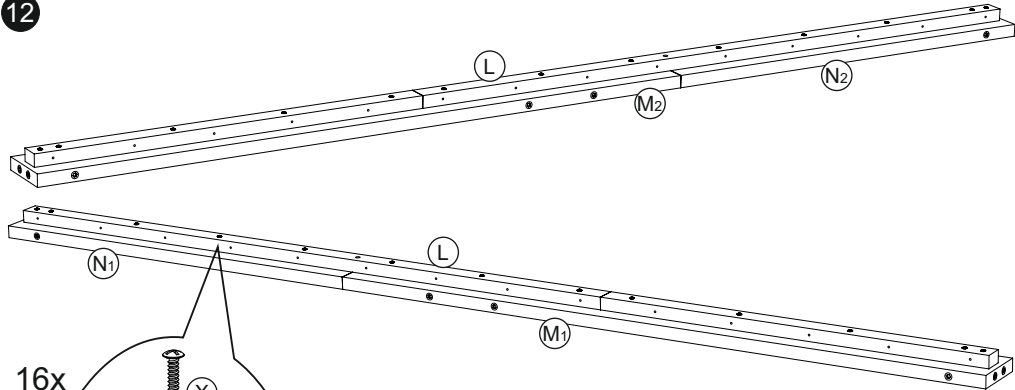

16x

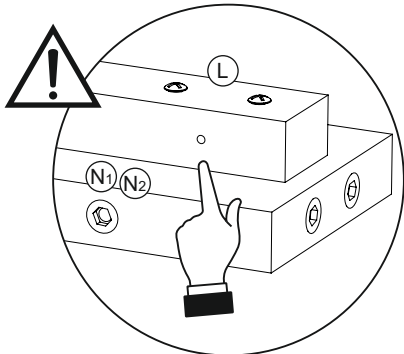
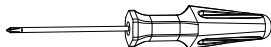
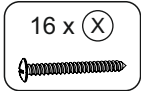
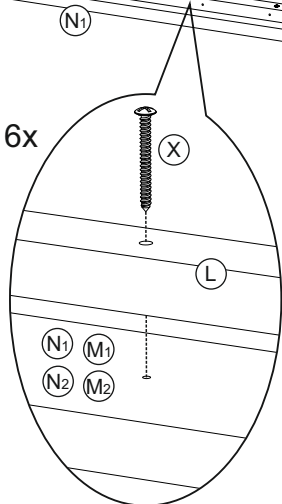

13

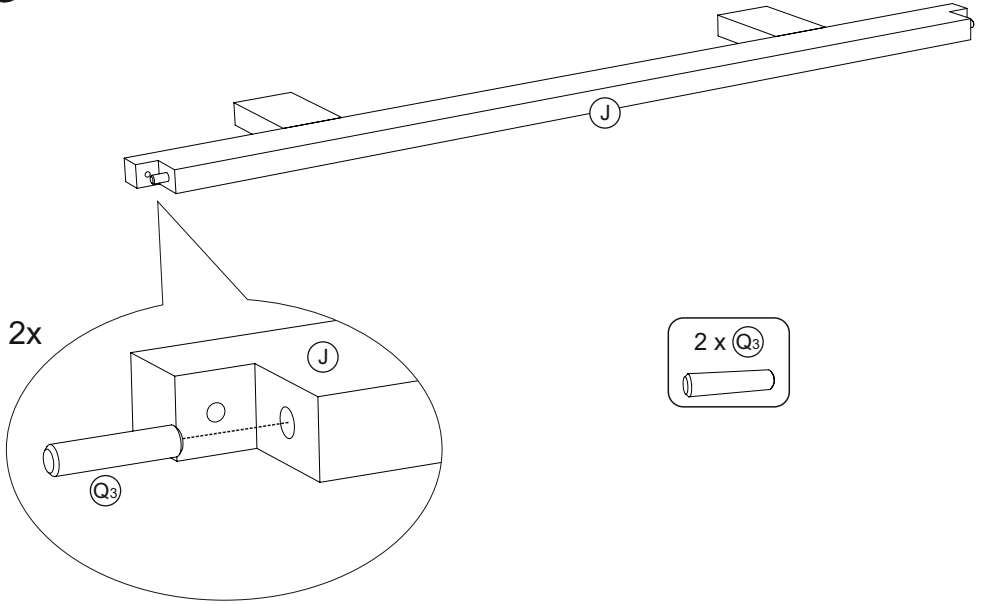

14

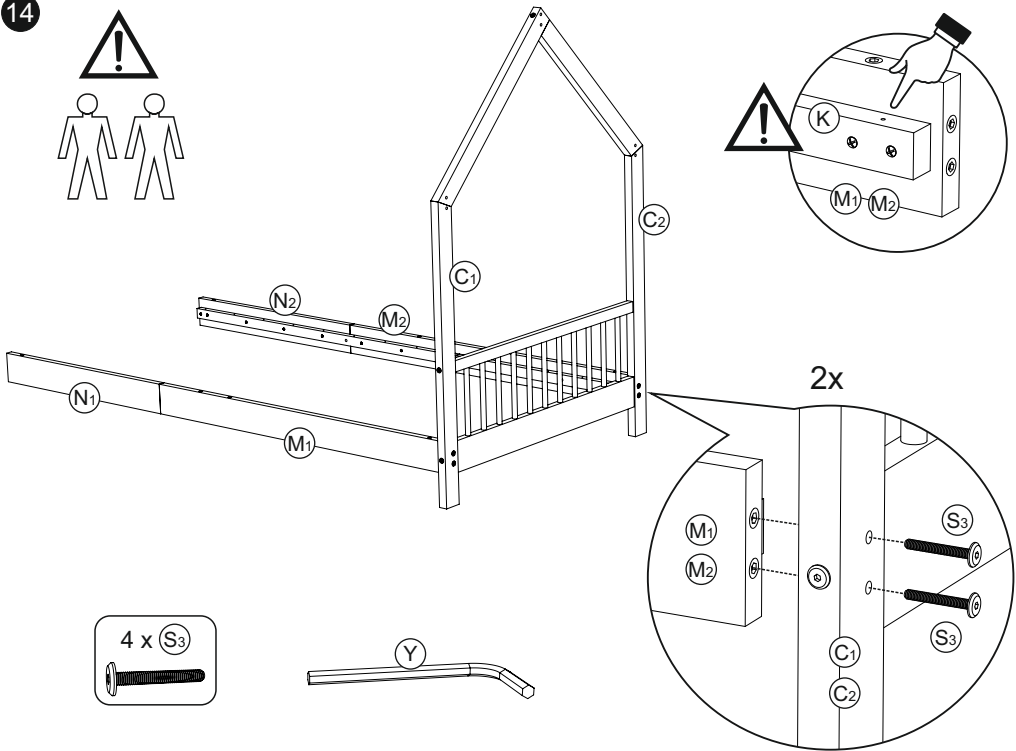

15

2x

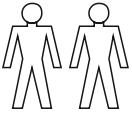
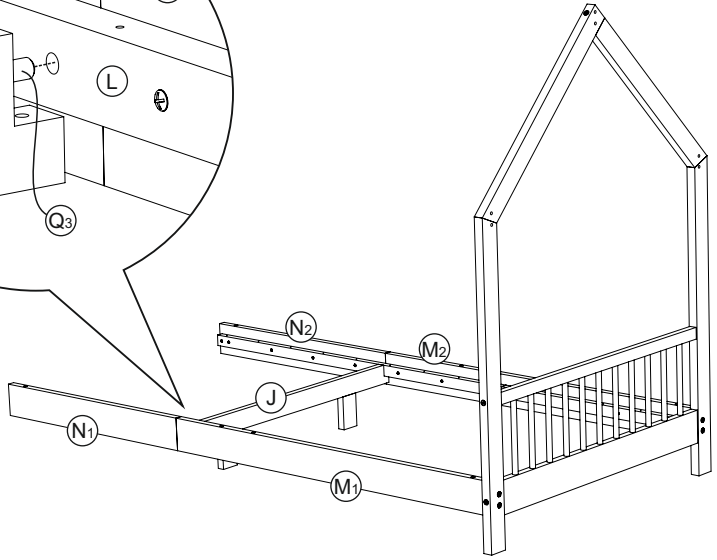
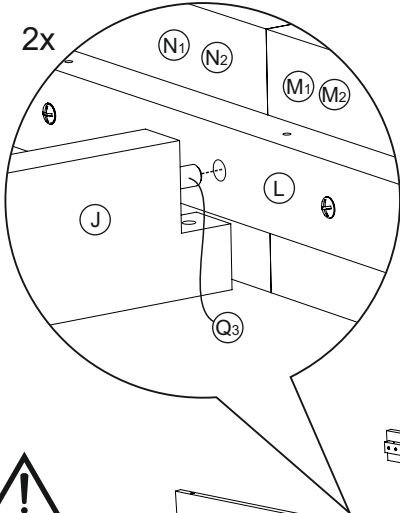

16

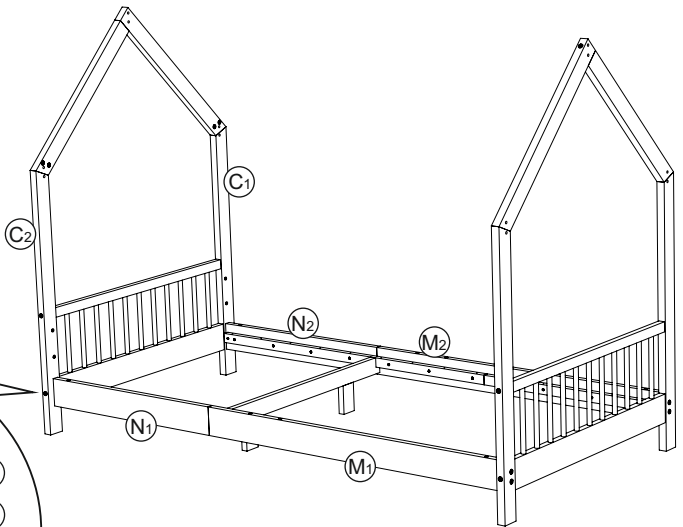
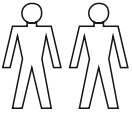

2x

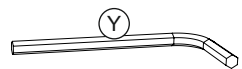
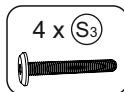
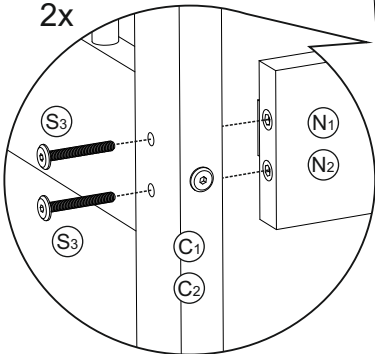

17

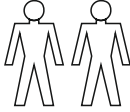

2x

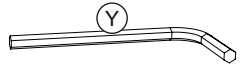
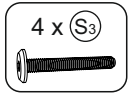
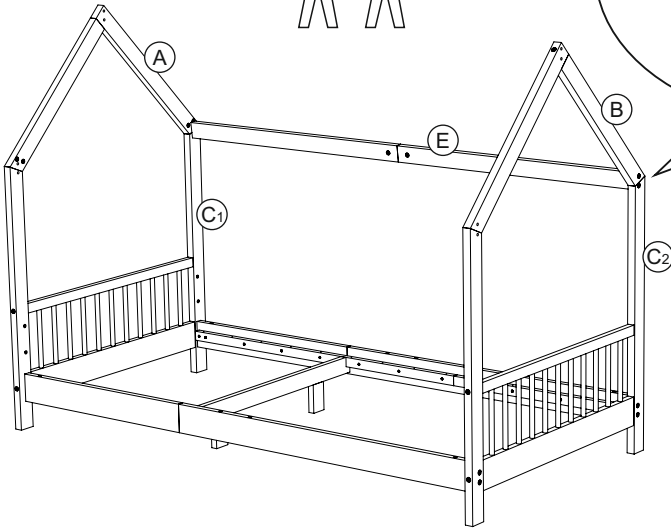
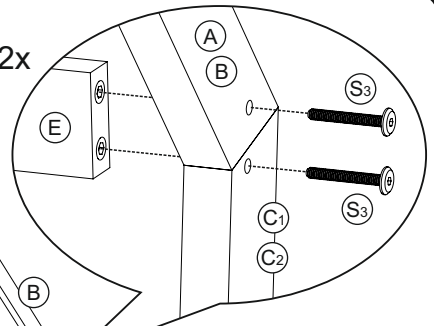

18

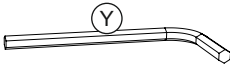

2x

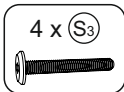
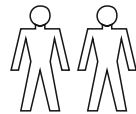
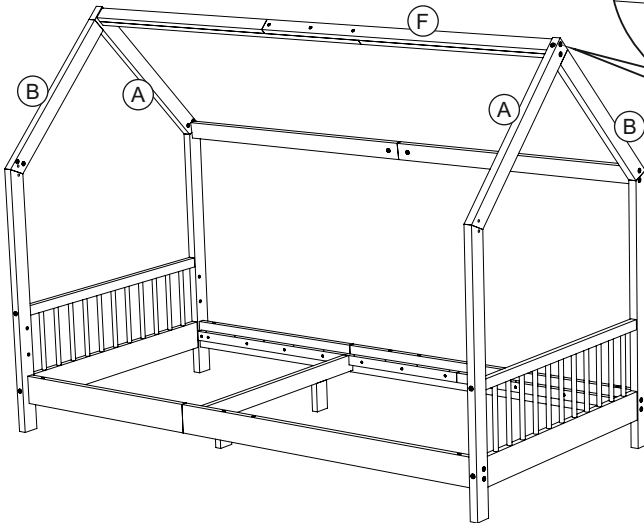
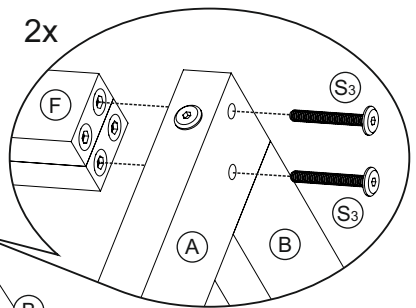

19

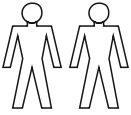

28x

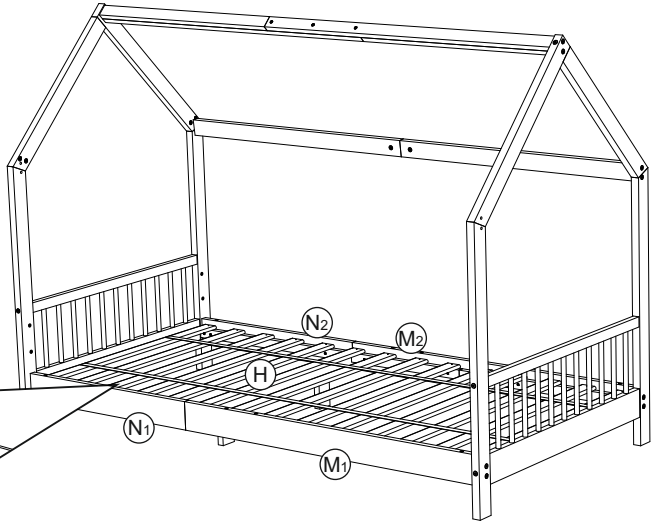
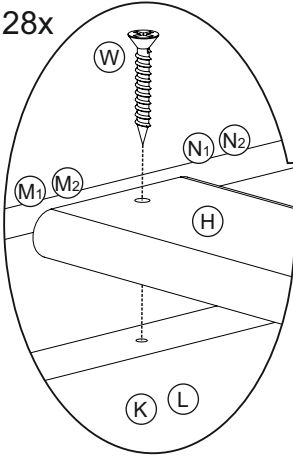

28 x (W)

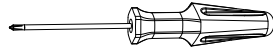

20

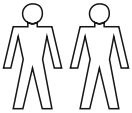

2x

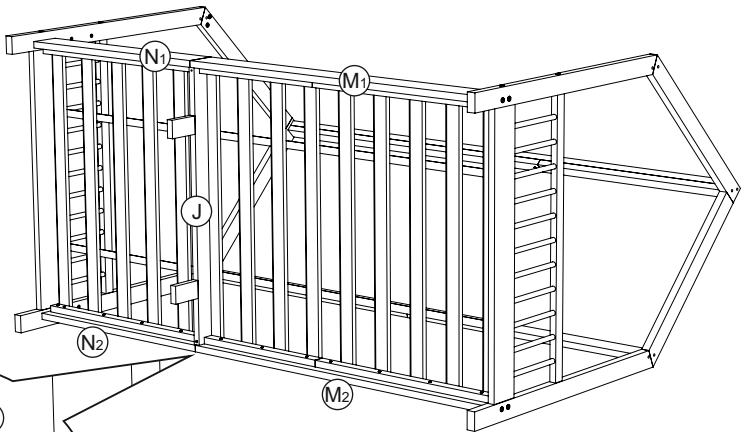
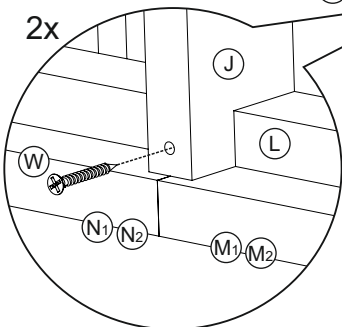

2 x (W)

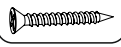
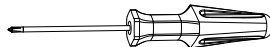

Versão 1
Version 1
Versión 1
Version 1
Version 1

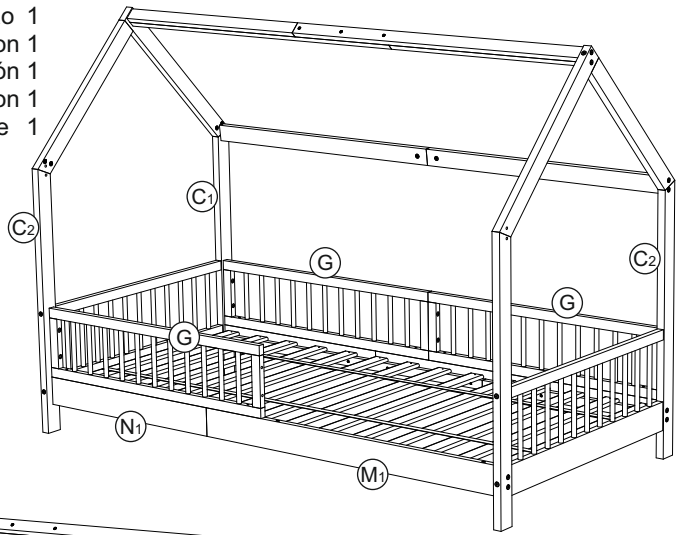

Versão 2
Version 2
Versión 2
Version 2
Version 2

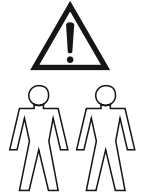
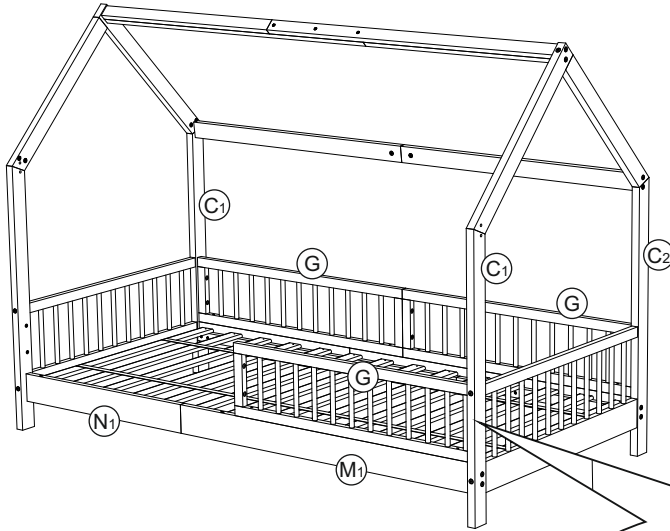

6x

6x

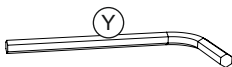
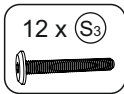
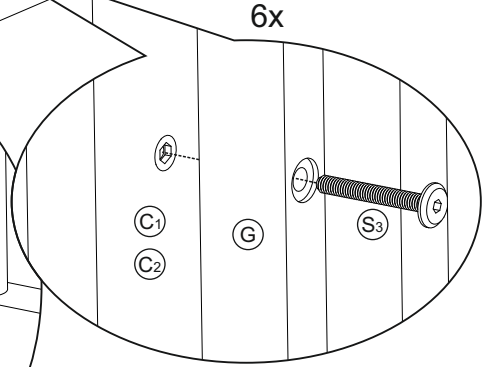
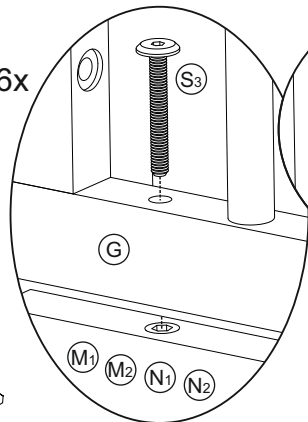

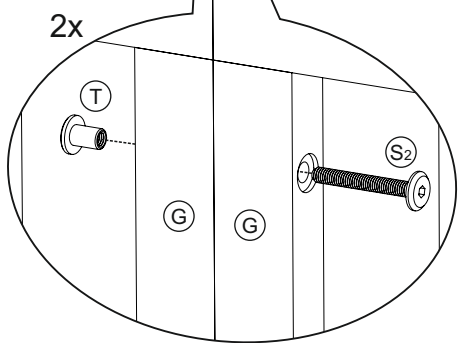
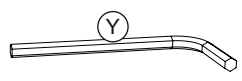
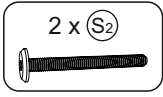
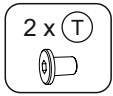
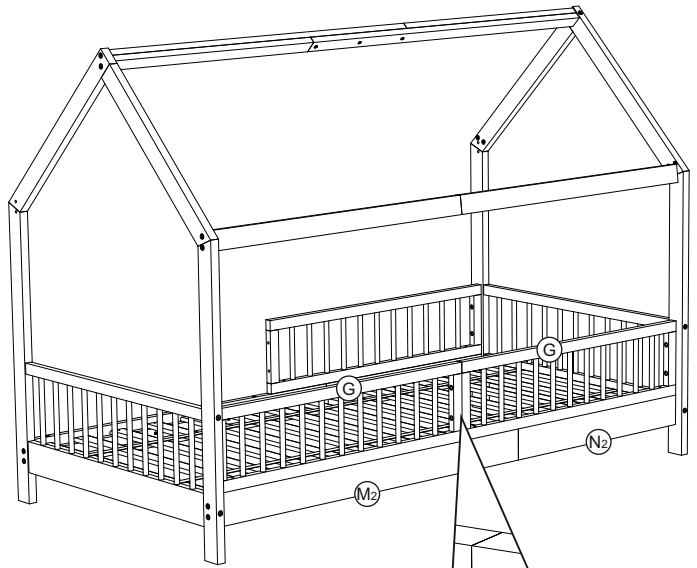

PT IMPORTANTE - LER ATENTAMENTE E GUARDAR PARA FUTURA REFERÊNCIA

ATENÇÃO

Faça uma inspeção periódica para certificar-se que os componentes estão em bom estado.

Antes de usar a cama certifique-se que todos os componentes estão bem montados e apertados, verifique regularmente para que se mantenha nesse estado.

Não deverá utilizar a cama junto a um radiador ou ventilador de ar quente.

Face ás diferente matérias primas utilizadas neste produto, madeira e ou seus derivados, pode existir uma variação na tonalidade da cor nos diferentes elementos deste artigo.

LIMPEZA

Para limpar a cama utilize um pano húmido e para a enxugar um pano macio.

Nunca use agentes de limpeza abrasivos.

O descuido na utilização da mobília de madeira pode causar danos à mesma.

GB IMPORTANT - READ CAREFULLY AND KEEP FOR FUTURE REFERENCE

WARNING

Remember to inspect your cot regularly for wear or accidental damage, and for the security of components. Before using this cot ensure all assembly fixings are properly tightened, and remember to regularly check that they remain so.

If possible, do not place your cot next to a radiator or hot air vent.

It is normal when painting or varnishing natural products such as wood or its derivatives that some variation in colour tone may occur on parts of this product.

COT CARE

This cot should be wiped with a damp cloth and buffed dry.

The use of abrasive cleaners is not recommended. Simply wipe clean and buff with a soft dry cloth.

Careless handling or movement of wooden furniture can damage it.

ES IMPORTANTE - LEER ATENTAMENTE Y GUARDAR PARA FUTURO USO

ADVERTENCIA

Recuerde inspeccionar la cuna periódicamente por desgaste o daños accidentales y por la seguridad de sus componentes.

Antes de usar la cuna, asegúrese que las partes de montaje estén bien apretados y recuerde inspeccionar regularmente para que se mantengan así.

Si es posible, no ponga la cuna cerca de ningún radiador o salida de aire caliente.

Cuando se aplica pintura o barniz a productos naturales como la madera o sus derivados, es normal que aparezcan variaciones en el tono del color en partes este artículo.

EL MANTENIMIENTO DE LA CUNA

La cuna se debe limpiar con un trapo ligeramente húmedo y secada suavemente.

El uso de productos de limpieza abrasivos no se recomienda. Simplemente limpiar y secar con trapo suave.

Manejar o mover muebles de madera sin cuidado puede causar daños.

FR IMPORTANT - LIRE ATTENTIVEMENT ET GARDER POUR UN USAGE FUTUR

ATTENTION

Contrôlez régulièrement votre lit: usure ou dégâts et vérifiez la sécurité des composants.

Avant d'utiliser le lit, vérifiez que toutes les vis soient bien serrées, et n'oubliez pas de répéter cette vérification régulièrement.

Ne jamais placez votre lit près d'une source de chaleur.

Une différence de couleur sur les éléments de ce produit est possible par la peinture ou le vernissage des produits naturels comme le bois.

ENTRETIEN

Entretenez le lit à l'aide d'un chiffon humide. Séchez ensuite.

N'employez jamais des produits abrasifs.

Prenez attention en déplaçant le lit car il y a risque d'endommager les meubles en bois.

NL

BELANGRIJK - AANDACHTIG LEZEN EN BIJHOUDEN VOOR EEN LATER GEBRUIK

WAARSCHUWING

Controleer uw bed regelmatig op slijtage of eventuele schade , en op de veiligheid van de onderdelen.

Voor dat U het bed gebruikt zie na dat alle vijzen korrekkt zijn aangedraaid. Zie dit regelmatig na.

Indien mogelijk, plaats uw bed niet in de nabijheid van een radiator of warme luchtbron.

Een kleurverschil op onderdelen van dit product is mogelijk door het schilderen of vernissen van natuurlijke producten zoals hout.

ONDERHOUD

De bed moet onderhouden worden met een vochtige doek en daarna drooggewreven.

Gebuik geen schuurmiddelen Wrijf gewoon droog met een zachte doek.

Onzorgvuldig gebruik van een houten meubel kan schade eraan veroorzaken.

GARANTIA:

Este produto tem uma garantia de 2 Anos.
Conserve o talão de compra junto desta Garantia.
Este talão deve ser apresentado em caso de eventual reclamação.

GARANTÍA:

Este producto tiene una garantía de 2 Años.
Mantenga el ticket de compra junto con esta garantía.
Este ticket debe ser presentado en caso de una eventual reclamación.



FABRICADO EM PORTUGAL
MADE IN POTUGAL
FABRICADO EN PORTUGAL
FABRIQUÉ AU PORTUGAL

Distribuidor:
MODELO CONTINENTE HIPERMERCADOS, SA
Sede: Rua João Mendonça, n° 505
4464-501 Senhora da Hora
PORTUGAL